



Finish, Culet Size, and Girdle Thickness: Categories of the GIA Diamond Cut Grading System

This booklet summarizes the relationship of Finish, Culet Size, and Girdle Thickness to the GIA Cut Grading System for round brilliant diamonds. It is intended to help members of the jewelry trade better understand the attributes of diamond appearance, and how those attributes are evaluated within the GIA Cut Grading System.

Finish—Polish and Symmetry

In the GIA Cut Grading System for standard round brilliant diamonds, finish (for Polish and Symmetry features) is factored into the final overall cut grade as follows:

- **To qualify for an Excellent cut grade, polish and symmetry must be Very Good or Excellent.**
- **To qualify for a Very Good cut grade, both polish and symmetry must be at least Good.**
- **To qualify for a Good cut grade, both polish and symmetry must be at least Fair.**
- **To qualify for a Fair cut grade, both polish and symmetry must be at least Fair.**
- **A Poor cut grade is assigned when either polish or symmetry is Poor.**

To determine the relationship between finish and overall cut quality, GIA conducted extensive observation testing of numerous diamonds using standardized lighting and viewing conditions. Observations of diamonds with comparable proportions, but differing in their polish and symmetry categories, were analyzed to determine the effects of finish on overall cut appearance. In this way, GIA found that a one grade difference between the other aspects of a diamond's cut grade and its polish and symmetry assessments did not significantly lower a trained observer's assessment of face-up appearance, and could not be discerned reliably with the unaided eye—e.g., polish and/or symmetry descriptions of Very Good did not cause observers to lower their assessment of a diamond that would otherwise receive an overall cut grade of Excellent.

©2009 The Gemological Institute of America. All rights reserved. The Gemological Institute of America (GIA) grants you a one-time, non-exclusive license to reproduce in print form this booklet solely for non-commercial, private use to reference the GIA Diamond Cut Grading System within an individual organization. This booklet may also be reproduced and used electronically in circumstances where such use is limited to the private, internal business use by the individual or firm to whom GIA provides the material. The material may not be modified in any way. GIA retains all rights to the material, and all other use is prohibited without the express, written permission of GIA.



Contributors: T. Blodgett, R. Geurts, A. Gilbertson, A. Lucas, D. Pay, I. Reinitz, J. Shigley, K. Yantzer, C. Zink
Editor: Brooke Goedert Design and layout: Richard Canedo, Al Gilbertson

Polish

In the GIA Cut Grading System “polish” refers to the quality of a diamond’s surface condition as a result of the polishing process or to blemishes created after the cutting process, often referred to as “wear and tear.” Polish features are located on the surface and do not visibly penetrate into the diamond as seen at 10X magnification. Polish is assessed on a scale consisting of Excellent, Very Good, Good, Fair, and Poor. A number of features are considered in the evaluation of polish. GIA Laboratory graders consider the amount and visibility of the polish features present. The general appearances of GIA’s five polish categories and various polish features are described below.

As with all other aspects of diamond grading, standard methodology and a controlled environment are used to evaluate polish consistently. The following steps are

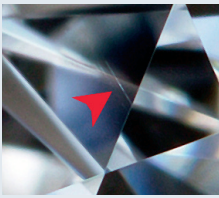
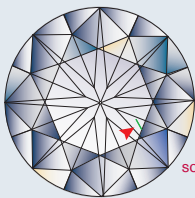
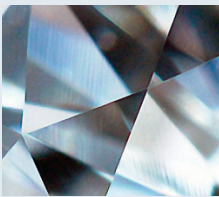
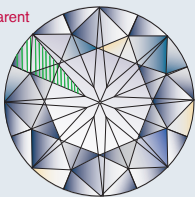
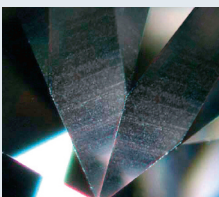
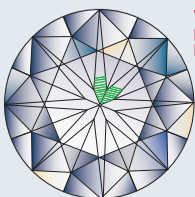
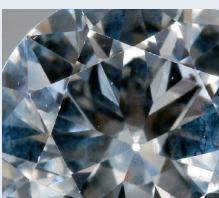
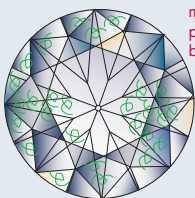
performed at 10X magnification with either a fully corrected loupe or a gemological microscope under darkfield illumination to assess polish (the final result in the GIA Laboratory is an objective consensus of independent grader opinions): (1) The diamond is first examined face-up, girdle-to-girdle to gain an initial impression of the polish; (2) The diamond is then examined one section at a time, through both the crown and pavilion, to locate and identify the specific polish features present; (3) The diamond is again examined face-up, girdle-to-girdle, and this time viewed in at least four different positions with a loupe; some features may be more or less apparent depending on the orientation of the diamond; (4) A verbal polish description is assigned that considers the diamond’s overall face-up appearance as well as polish features seen in any view. Emphasis is placed on the diamond’s face-up appearance as seen with a 10X loupe.

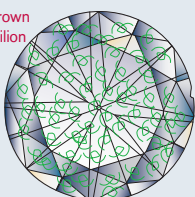
CATEGORIES		
		<p>Excellent: ranges from no polish features to a few minute features that can be viewed face-up with difficulty at 10X magnification.</p> <p>Some typical features that would be allowed in the Excellent category include a few pits or nicks, a small area with faint transparent polish lines, or negligible scratches or abrasion.</p> <p><i>* Although a diamond with a few minute polish features might qualify for the Excellent polish category, the same diamond could not qualify for a Flawless clarity grade. Only diamonds with no polish features visible at 10X magnification qualify for a Flawless clarity grade.</i></p>
		<p>Very Good: minor polish features are seen face-up at 10X magnification.</p> <p>Some typical features that would establish a Very Good category include several pits or nicks, a few small areas of abrasion, a limited extent of moderate transparent polish lines, a small area with faint white polish lines, several faint scratches or a few heavier white scratches, faint lizard skin, or a small area of very faint burn marking.</p>
		<p>Good: noticeable polish features are seen face-up at 10X magnification. The luster of the diamond may be affected when viewed with the unaided eye.</p> <p>Some typical features that would establish a Good category include moderate to heavy transparent polish lines, white polish lines, many heavy scratches, lizard skin or burn marks.</p>
		<p>Fair: obvious heavy polish features are seen face-up at 10X magnification. The luster of the diamond is affected when viewed with the unaided eye.</p> <p>Some typical features that would establish a Fair category include heavy white polish lines or burned facets over most of the crown or pavilion.</p>
		<p>Poor: prominent heavy polish features are seen face-up at 10X magnification. The luster of the diamond is significantly affected when viewed with the unaided eye.</p> <p>Some typical features that would establish a Poor category include heavy white polish lines or burned facets over most of the crown and pavilion.</p>

FEATURES

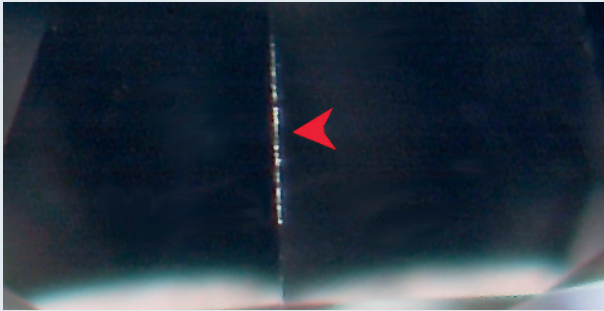

Abrasion: area of minute scratches or pits along a facet edge producing a fuzzy white line instead of a sharp facet junction.

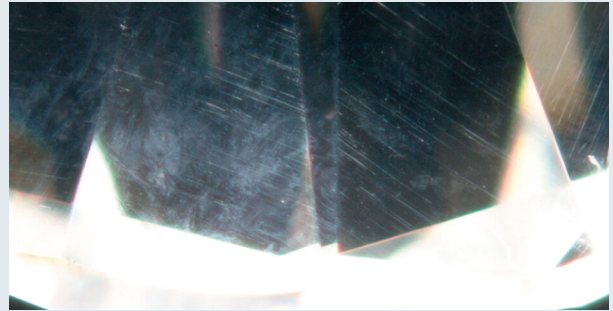

Burn mark or burned facet: whitish haze across a facet or a concentrated area caused by excessive heat during polishing or occasionally by a jeweler's torch.



Lizard skin: transparent uneven texture confined to one facet; caused by polishing a facet off-grain, at the hardest direction near a cleavage plane.

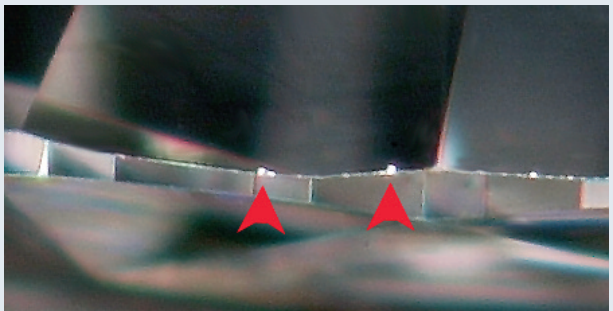

Nick: small notch on a facet junction, usually along the girdle or culet; minute chip with no visible depth at 10X magnification.

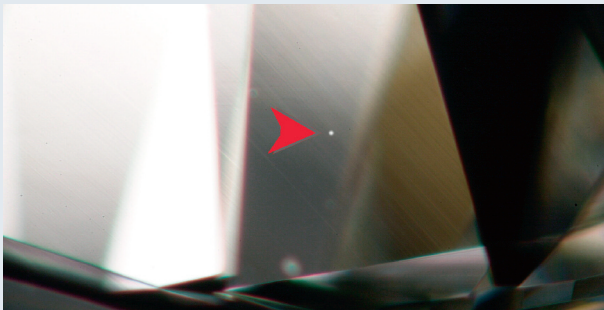

Pit: tiny opening appearing as a white dot.

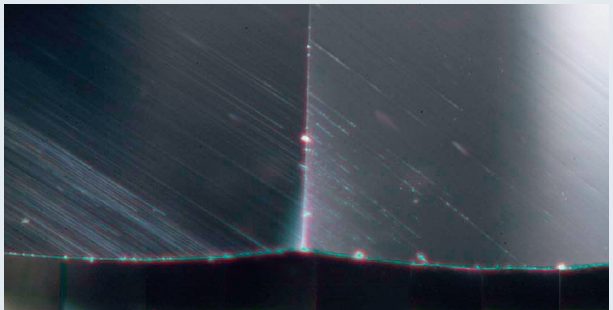

Polish lines: parallel lines left by the polishing process; may appear white or transparent.

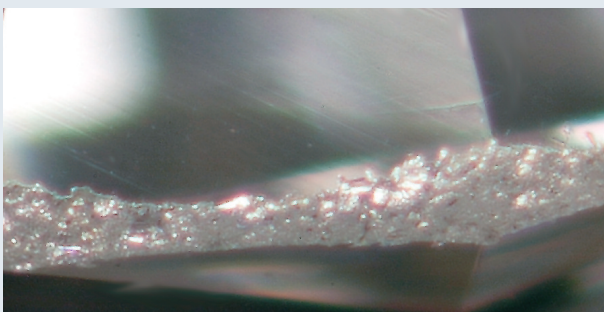

Rough girdle: irregular pitted or granular surface of a bruted girdle due to pits and nicks.

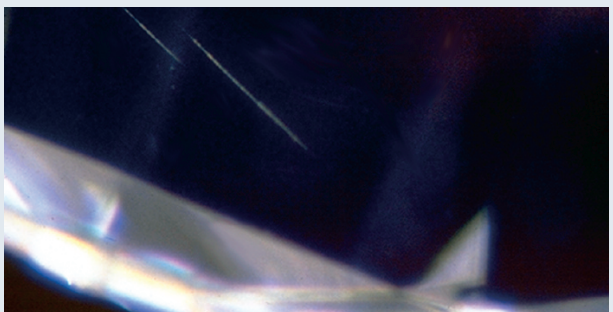







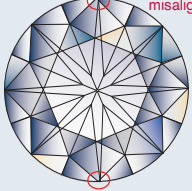

Scratch: surface mark normally seen as a fine white line, curved or straight.

Symmetry

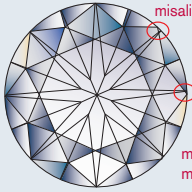
In the GIA Cut Grading System, “symmetry” refers to the exactness of the shape of a diamond and the symmetrical arrangement and even placement of the facets. As with polish, a number of features are considered in the evaluation of symmetry; these are defined and illustrated below.

Symmetry features can be subdivided into two types: proportion-related and facet-related. Due to a polished diamond’s three-dimensional nature, the presence of one symmetry feature may be linked to others. GIA Laboratory graders consider the extent and visual appearance of any symmetry features present.

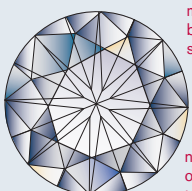
The general appearances of GIA’s five symmetry categories are described below. The following steps are performed at 10X magnification with either a fully corrected loupe or gemological microscope under darkfield illumination to determine the symmetry of a polished diamond (the final result is an objective consensus of independent grader opinions): (1) The diamond is first examined face-up, girdle-to-girdle in order to gain an initial impression of the symmetry; (2) The diamond is then rotated in profile view to reveal any symmetry features that are best seen in this position — such as non-pointing, misalignment, wavy girdle, girdle thickness variation, table and girdle not parallel, crown

CATEGORIES	
	 <p>Excellent: ranges from no symmetry features to minute symmetry features that can be viewed face-up with difficulty at 10X magnification.</p> <p>Some typical features that would be allowed in the Excellent category include misaligned, misshapen, non-pointed, or extra facets that are barely visible.</p>
	 <p>Very Good: minor symmetry features are seen face-up at 10X magnification.</p> <p>Some typical features that would establish a Very Good category include slight table or culet off-center, a slightly out-of-round outline, and/or minor misshapen, non-pointed or extra facets.</p>
	 <p>Good: noticeable symmetry features are seen face-up at 10X magnification. The diamond's overall appearance may be affected when viewed with the unaided eye.</p> <p>Typical features that would establish a Good category include any proportion feature that is noticeable: table or culet off-center, out-of-round outline, wavy girdle, table and girdle not parallel, girdle thickness variation, crown or pavilion angle variation, and/or many noticeable misshapen, misaligned, non-pointed, or extra facets.</p>
	 <p>Fair: obvious symmetry features are seen face-up at 10X magnification. The diamond's overall appearance is often affected when viewed with the unaided eye.</p> <p>Typical features that would establish a Fair category include any proportion feature that is obvious: table or culet off-center, out-of-round outline, wavy girdle, girdle thickness variation, crown or pavilion angle variation, many obvious misshapen or extra facets, misalignment or non-pointing on most of the facets, and/or an obvious missing facet such as a bezel or main.</p>
	 <p>Poor: prominent symmetry features are seen face-up at 10X magnification. The diamond's overall appearance is significantly affected when viewed with the unaided eye.</p> <p>Typical features that would establish a Poor category include any proportion feature that is prominent: table or culet off-center, out-of-round outline, wavy girdle, girdle thickness variation, crown or pavilion angle variation, or prominent faceting distortion.</p>

angle variation and pavilion angle variation; (3) The diamond is again examined face-up, girdle-to-girdle, and this time viewed in at least four different positions with a loupe; some features may be more or less apparent depending on the orientation of the diamond; (4) The grader checks the values of the optically measured symmetry features to evaluate the degree of misalignment, especially culet off-center, table off-center, and out-of-round; (5) A verbal symmetry description is assigned that considers the diamond's face-up appearance as well as symmetry features seen in profile view. Emphasis is placed on the diamond's face-up appearance as seen with a 10X loupe.

While this chart focuses on symmetry evaluation as part of the GIA Cut Grading System for standard round brilliant diamonds, most of the criteria apply similarly to fancy shapes with the addition of some specific guidelines in regard to shape and lines of symmetry.

Variations in crown height and/or pavilion depth result from one or more of the following deviations: wavy girdle, table and girdle not parallel, crown angle variation, pavilion angle variation, and/or girdle thickness variation.

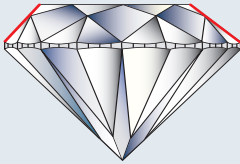
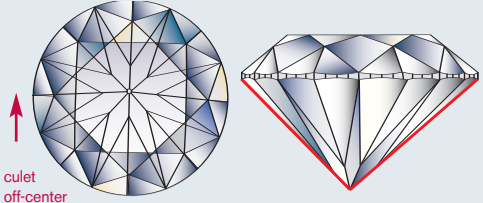
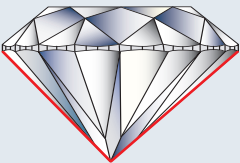
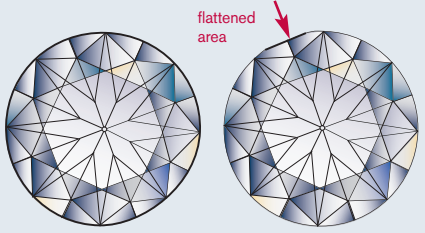
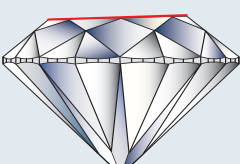
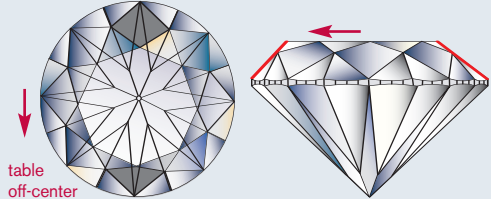
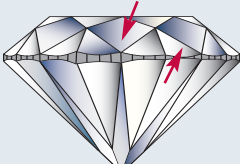
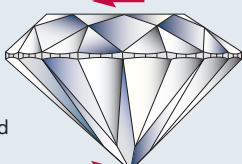
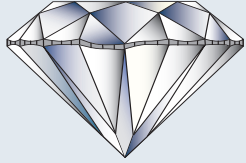
PROPORTION-RELATED SYMMETRY FEATURES		
<p>Crown angle variation</p> <p>all eight crown angles are not equal; typically related to table off-center.</p> 	<p>Culet off-center</p> <p>deviation of the culet from the central position on the pavilion; results in the cross-line formed by lower half facet junctions to be bowed or bent. When viewed through the table, more of the pavilion is seen to one side of the culet than the other.</p> 	
<p>Pavilion angle variation</p> <p>all eight pavilion angles are not equal; typically related to culet off-center.</p> 	<p>Out-of-round</p> <p>deviation from the circular shape of a round diamond; a flattened area such as that created by a natural or extra facet also constitutes out-of-round. Comparison of the minimum and maximum diameters can help assess roundness.</p> 	
<p>Table and girdle not parallel</p> <p>the girdle plane is not parallel to the table.</p> 	<p>Table off-center</p> <p>deviation of the table from the central position on the crown; results in opposing bezels of differing sizes. When viewed through the table, more of the pavilion is seen to one side of the culet than the other.</p> 	
<p>Girdle thickness variation:</p> <p>variations of the girdle thickness at "valley" and "hill" positions.</p> 	<p>Table/culet alignment</p> <p>displacement of the table facet and culet in opposite directions.</p> 	<p>Wavy girdle</p> <p>undulating girdle.</p> 

FACET-RELATED SYMMETRY FEATURES

Extra facet

additional facet placed without regard for symmetry and not part of the standard cutting style; typically causes an out-of-round outline, short facets or misshapen facets.

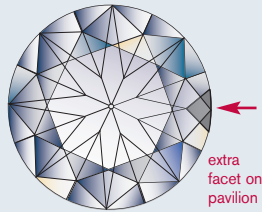

Misalignment

displacement of the crown and pavilion facets in relation to each other.

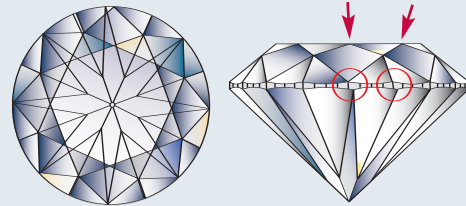

Missing facet

asymmetrically missing or deleted facet.

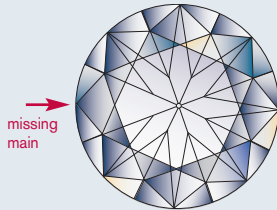

Misshapen facet

difference in shape or size between one facet and another of the same type; or distortion of a given facet.

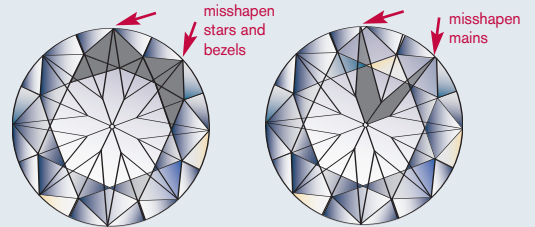

Natural

part of the original diamond crystal's surface that remains on the polished diamond; typically causes an out-of-round girdle outline, short facets or misshapen facets.

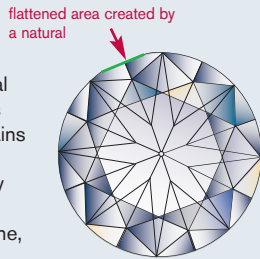

Non-octagonal table

the table is not a regular octagon; results in misshapen star and bezel facets.

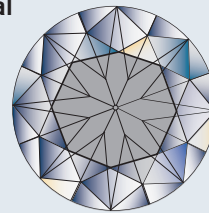

Non-pointing

facet that does not reach its prescribed location (short facet) or is incompletely finished (open facet), resulting in adjoining facets not meeting at precise points.

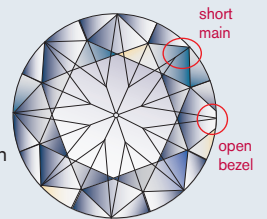

Culet Size

The culet is a polished facet placed parallel to the table, the purpose of which is to prevent damage to the point. Culet size is an important element in GIA’s Cut Grading System, as it can affect evaluations of the face-up appearance.

To determine the significance of culet size, GIA researchers used computer modeling and visual observations to examine the effects of these proportions on face-up appearance — for example, eye-visible culets that may disrupt the face-up pattern.

In the GIA Laboratory, graders first assess culet size face-up, looking through the table facet at 10X magnification. In GIA’s International Diamond Grading System™, culet size is described as None, Very Small, Small, Medium, Slightly Large, Large, Very Large, or Extremely Large. If there is no culet facet the size is reported as None. When all eight mains meet each other, it may be referred to as “pointed.” If the culet is at more than a slight angle to the table facet, the size is also reported as None, as it is no longer considered a culet but an extra facet.

Culet size can be measured through the use of a non-contact optical measuring device or with the GIA Multi-Purpose Gemological Reticule and a standard gemological microscope. These measurements can be expressed as a percentage relative to the average diameter of the diamond, which graders may use as a guide when making visual assessments. Because measured results are susceptible to the variability inherent in measurement device tolerances and clarity characteristics as well as irregularities in shape or angle, the final call is determined by visual observation. To support their visual assessment of culet size, GIA Laboratory graders use photographic references. The accompanying chart provides definitions and typical examples for each description and their relationship to the calculated culet-size percentages.

$$\text{Culet Size \%} = \frac{\text{culet size (mm)}}{\text{average diameter}} \times 100$$

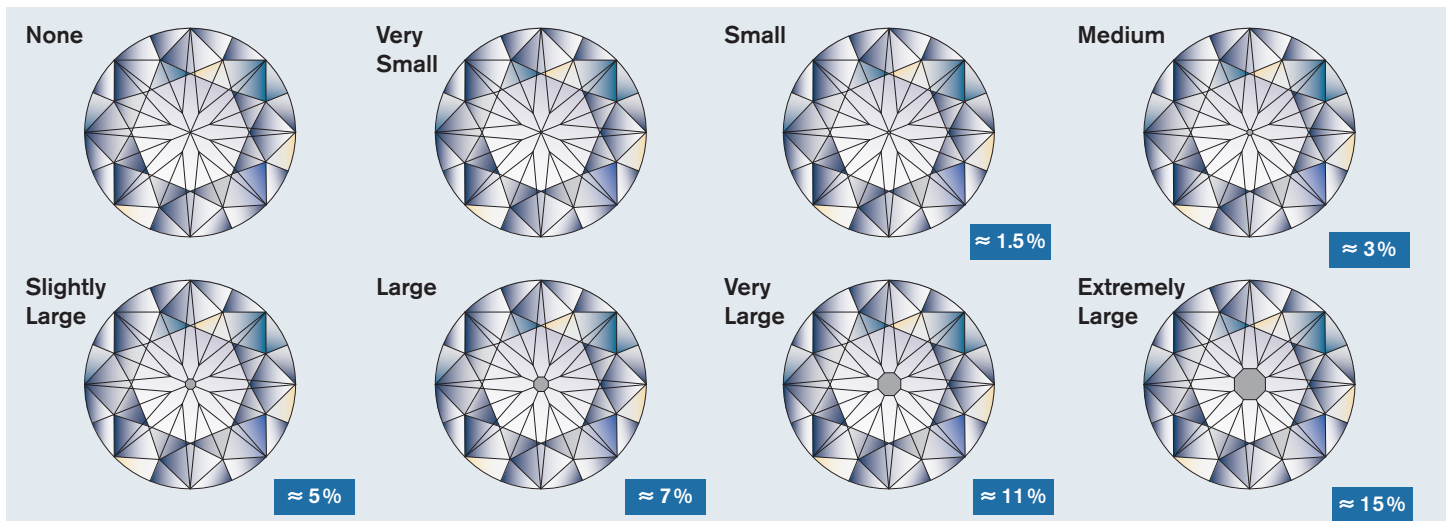

Culet size percentages shown here represent typical values (not the highest or lowest point) for culets that are octagonal in shape. None, Very Small, and Small are best evaluated visually since these fine measurements are more susceptible to measurement tolerances and the presence of clarity characteristics. For these same reasons, in addition to the fact that the culet may be irregular or not parallel to the table, all assessments must be verified visually.

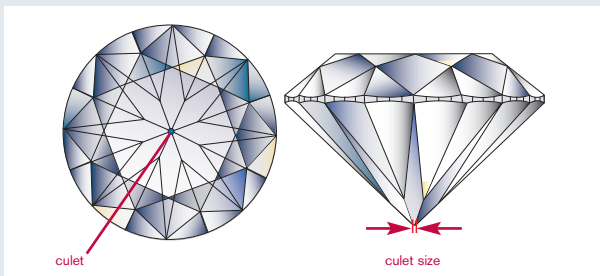

The culet is a facet placed at the tip of the pavilion where the mains meet to reduce the risk of damage on loose diamonds. Although the definition of culet is limited to the facet located at the bottom of the pavilion, this term is commonly used to refer to this area in general.

Girdle Thickness

The girdle is a narrow section separating the crown from the pavilion and functions as the diamond’s setting edge, reducing the risk of damage when sufficiently thick. The girdle of a standard round brilliant diamond is scalloped and consists of 16 “valley” and 16 “hill” positions created by the final brillianteing (cutting). Both the average girdle thickness percentage and the minimum/maximum verbal descriptions are important elements in the GIA Cut Grading System. A thick girdle can contribute toward a heavier diamond than its face-up appearance warrants, and a thin girdle can increase the risk of damage such as chipping. GIA Laboratory graders visually assess girdle thickness at 10X magnification with the diamond in profile view, and consider each of the 16 valley positions and their thicknesses relative to the diameter of the diamond.

The average girdle thickness is measured strictly by an optical device and its percentage calculated using the provided formula. In contrast, the minimum and maximum verbal descriptions rely on the judgment of GIA Laboratory graders at 10X magnification. Girdle thickness is assessed as a range from the thinnest to thickest valley positions; these valley positions – or thin areas – are located where the upper and lower half facets come closest to meeting. Girdle thickness is verbally described as Extremely Thin, Very Thin, Thin, Medium, Slightly Thick, Thick, Very Thick, and Extremely Thick.

Minimum and maximum girdle thickness can be measured through the use of a non-contact optical measuring device or with the GIA Multi-Purpose Gemological Reticule and a standard gemological microscope. These measurements can be expressed as a percentage relative to the average diameter of the diamond, which graders may use as a guide when making visual assessments. Girdle thickness assessments (min. and max.) must continue to rely on visual observations

because measured results are susceptible to the variability inherent in measurement device tolerances and clarity characteristics, as well as irregularities in shape or angle. This is especially true when distinguishing between extremely thin and very thin girdles.

An extra facet, natural, chip, cavity, or indented natural located at the girdle edge can narrow the girdle, in which case the remaining area is considered in the thickness assessment. If a “knife-edge” is created, the girdle thickness is reported as Extremely Thin. When a chip, cavity, or indented natural breaks through the girdle onto the crown and pavilion, the effect on the girdle thickness is not considered in the assessment. To support their visual assessment of girdle thickness, GIA Laboratory graders use photographic references as well as the girdle thickness percentages of the “valley” positions. A description of the girdle thickness is assigned based on the visual appearance at 10X magnification. When both the thinnest and thickest results fall in the same category, a single description is reported, such as Very Thin. More often, however, thickness is reported as a range from the thinnest to thickest valley areas, e.g., Very Thin to Medium. Variation in girdle thickness is also accounted for in the assessment of the diamond’s symmetry or in evaluation of painting or digging out (see below). The girdle’s condition may be bruted — the surface produced by the process used to shape the round diamond — or it may be polished or faceted. The girdle’s thickness is assessed the same, regardless of its condition. The examples shown illustrate approximate sizes for visual comparison and are not boundaries.

$$\text{Girdle Thickness \%} = \frac{\text{girdle thickness (mm)}}{\text{average diameter}} \times 100$$

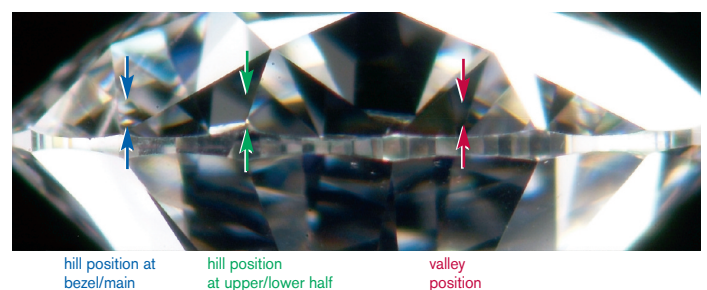
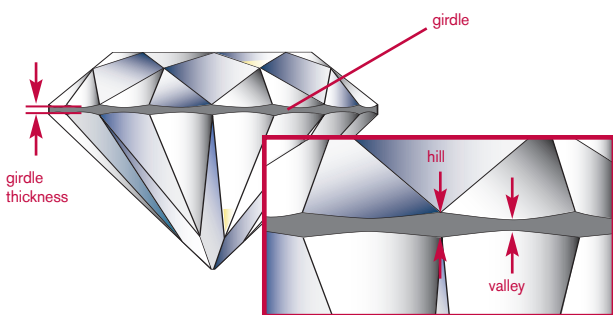

Girdle thickness – as described by the GIA Laboratory – represents the thinnest and thickest “valley” positions on the girdle of the round brilliant – i.e., thin areas located where the upper and lower half facets meet – relative to the average diameter of the diamond.

Extremely Thin

Crown and pavilion meet with no girdle in between, creating a sharp edge; may be referred to as a "knife-edge."

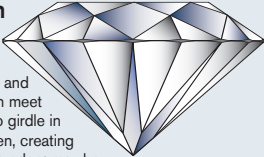

Very Thin

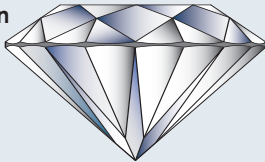

Thin

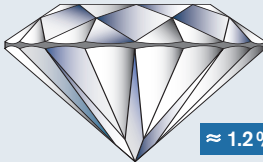

≈ 1.2% valley
≈ 2.9% hill

Medium

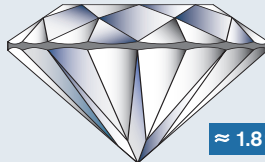

≈ 1.8% valley
≈ 3.5% hill

Slightly Thick



≈ 2.5% valley
≈ 4.2% hill

Thick



≈ 3.5% valley
≈ 5.2% hill

Very Thick



≈ 5.0% valley
≈ 6.7% hill

Extremely Thick

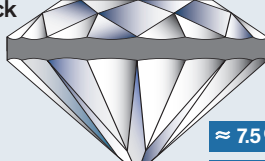

≈ 7.5% valley
≈ 9.2% hill

Girdle thickness percentages shown here represent typical values (not the highest or lowest point) for symmetrical diamonds with evenly scalloped girdles. Extremely Thin and Very Thin are best evaluated visually since these fine measurements are more susceptible to measurement tolerances in the presence of clarity characteristics. For these same reasons, in addition to the fact that the girdle may be irregular or not perpendicular to the table, all assessments must be verified visually.

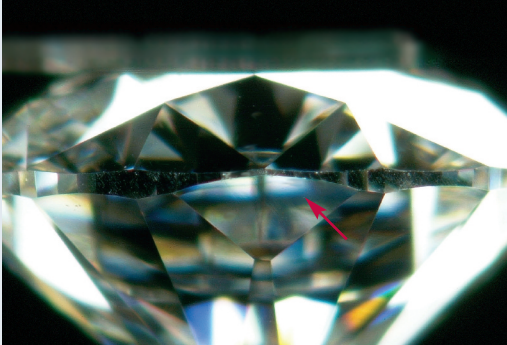

An extra facet on the pavilion side of this diamond narrows the girdle at a "hill" position. The girdle thickness in this example would be reported as a range from Thin – at the location of the extra facet – to Slightly Thick – the thickest "valley" position present.

Painting and Digging Out: A Type of Girdle Thickness Variation

Understanding Painting and Digging Out

While we illustrate here how to observe this visually, GIA calculates the extent of painting and digging out from the three-dimensional model produced by the non-contact measuring systems used to find a diamond's proportions and angles.

Visual Cues at the Girdle

In a diamond with a normal girdle, the girdle thickness at the points where the bezel facets meet the pavilion mains is roughly equal to the girdle thickness at the points where the center junctions of the upper half facets meet the center junctions of the lower half facets. With all of these positions being relatively equal, there's fairly even scalloping of the girdle all around the diamond.

During fashioning, the polisher uses techniques called "painting" and "digging out" to change the relative positions of the upper and/or lower half facets. As a result, the girdle edge at the half-facet junctions can become thicker or thinner relative to the girdle edge at the bezel-main junctions and their relative angles change.

Both techniques can be used to maximize weight yield, especially if a small difference can lift a diamond beyond an important weight threshold, such as the half-carat, one-carat or two-carat levels. Digging is also used to remove clarity characteristics located near the girdle. Moderate to strong painting or digging out will change the face-up appearance of a diamond, even if all of the facets are arranged symmetrically and the proportions fall within traditional ranges for better looking diamonds.

Painting

When painting, the cutter tilts the upper or lower half facets toward the bezel facets or pavilion mains. In a diamond with a painted girdle, the thickness of the points where the upper half facet junctions meet the lower half facet junctions is greater than the girdle thickness where the bezel facets meet the pavilion main facets.

Digging Out

Digging out is the opposite of painting. When digging out, the cutter tilts the upper and/or lower half facets, away from the bezel or pavilion main facets and toward each other. In a round brilliant with dug-out facets, the

girdle thickness at the points where the upper half facet junctions meet the lower half facet junctions is less than the girdle thickness at the points where the bezel facets meet the pavilion main facets.

Impact of Painting/Digging Out in the GIA Cut Grading System

The visual impact of painting and digging out varies with the combination of diamond proportions in a complex way. Among diamonds of typical proportions, GIA has found that most people prefer diamonds that are neither painted nor dug out beyond minimal thresholds. GIA calculates the extent of painting or digging out from the three-dimensional model produced by the non-contact measuring systems used to find a diamond's proportions and angles. This calculation is not yet available through Facetware. These charts are merely a guide to show the slight difference in girdle appearance, and how these slight differences in painting or digging out create differences in face-up appearance, affecting the final GIA cut grade accordingly.

For typical proportion combinations, observation testing confirmed that diamonds with painting and/or digging out beyond a certain degree were less preferred than diamonds of similar proportions with standard brillianteering. In agreement with these observations, the GIA Cut Grading System will take into account various extents and combinations of painting or digging out.

When a diamond is painted, face-up appearance is more strongly affected through painting of the pavilion than the crown. As pavilion painting increases, a diamond begins to look like a single-cut diamond (a round diamond with fewer facets) with strong wide areas of darkness in the pattern. In combination with crown painting, the effect of a dark and bright banded pattern is accentuated.

Face-up appearance is more sensitive to digging out. Strong digging out on the crown causes upper half facets to darken, blending with the bezel facets, which also darken. Digging out on the pavilion can cause the entire stone to have an interrupted pattern that takes on a strong gray appearance, lacking in contrast. Digging out on both the crown and pavilion causes the most extreme differences in appearance, darkening the center with unusual bands of dark and light in the reflection pattern.

Normal Girdle

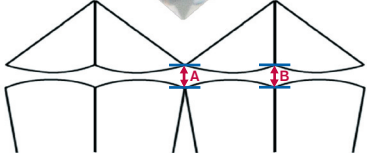
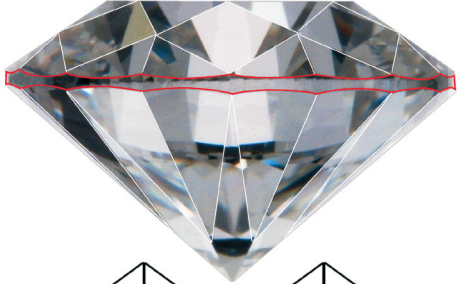
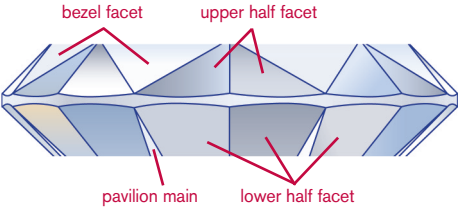

Painted Girdle

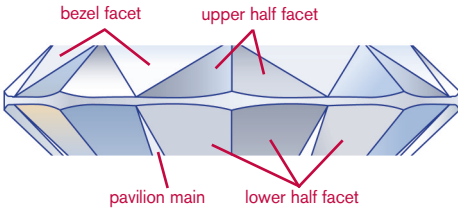

Dug Out Girdle

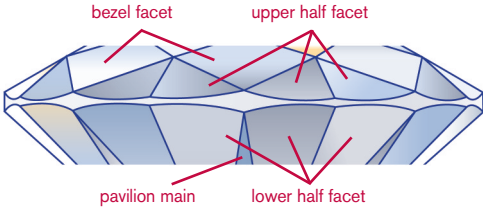

Crown Painting Only

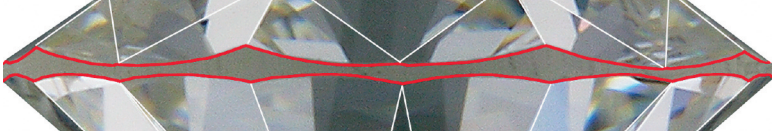
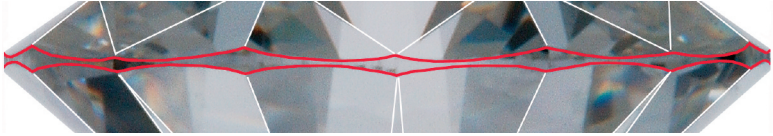

Categories of the GIA Diamond Cut Grading System

FEATURES OF PAINTING

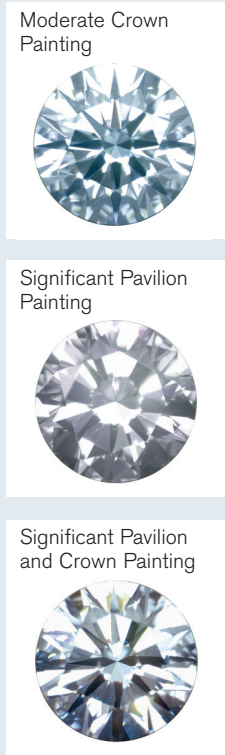

	Crown Only	Pavilion Only	Crown and Pavilion
Negligible (Excellent)			
Moderate (Very Good)			
Significant (Good)			
Severe (Fair)			

FEATURES OF DIGGING OUT

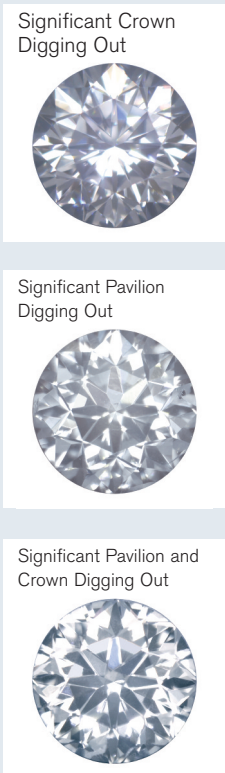

	Crown Only	Pavilion Only	Crown and Pavilion
Negligible (Excellent)			
Moderate (Very Good)			
Significant (Good)			
Severe (Fair)			